



b.o.b. Sistemi Idraulici S.p.A.

ITRunner®

AZIENDA CON SISTEMA
DI GESTIONE QUALITÀ
CERTIFICATO DA DNV
= ISO 9001 =

3 AXLES HOOKLIFT TRAILER ITR « 26.33 HD » MECHANIC SUSPENSIONS – TELESCOPIC ARM

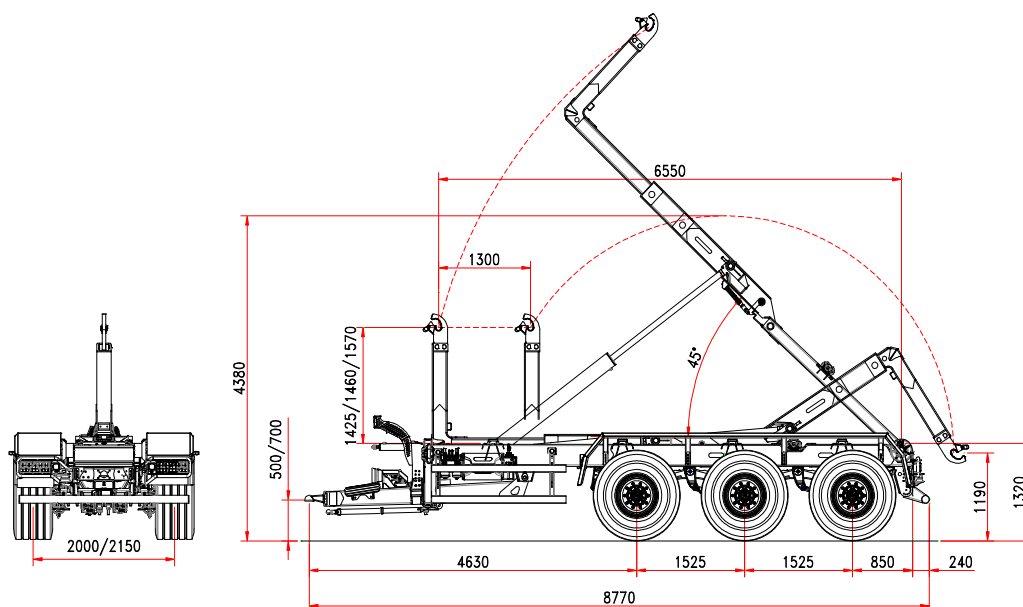

STANDARD FEATURES

HEAVY DUTY TRAILER AND HOOKLIFT STRUCTURE

CHASSIS

Frame section	300 x 100
Draw bar	silent block
Leaf spring suspension	Tridem 36 tons
Axles WHB	1.525 mm
Axles section (ADR type)	3 x 150
Axles	fixed+fixed+fixed
Track	2.000 mm
Brake drum	406 x 120
Braking system	hydraulic
Towing eye	fixed type
Support foot	2 x hydraulic
Wheels size	550/60-22,5
Front stab. cylinder 3 rd point	standard
Chassis loading level	1.320 mm

WEIGHT AND DIMENSIONS

Gross Trailer Weight (G.T.W.)	33 ton
Container handling cap.	5.500/7.500 mm.
Max speed	40 Km/h
(*) Tare	8.500 kg
(*) The trailer tare is referred to the basic unit without options & accessories	

TELESCOPIC ARM

run	1.300 mm
Hook level	1.425/1.460/1.570
Container internal/external locking	hydraulic
Tipping angle	45°
Hoist start cylinder	standard
Tipping capacity	26 ton
Lifting capacity	26 ton

OLEO DYNAMIC SYSTEM

Tractor hydraulics:	2 controls double acting
Trailer hydraulics:	
Cardan + piston pump	108 lt / 1.000 rpm
Oil tank	160 l
Max. pressure	320 bar
Flow control electro-hydraulic with ground manual levers and remote radio control Bobeasy	

Edit 06/2013

The technical details shown in this sheet are indicative and can be changed by the builder without prior notice.

B.O.B. Sistemi Idraulici S.p.A. – Regione Oltre Rea, 32 – 12060 Monchiero (CN) – Italia

P. I.V.A. 00496180043 – Tel.: +39 (0173) 780002/3 – Fax: +39 (0173) 780004

Internet: www.bobspa.com – e-mail: info@bobitalev.com