



b.o.b. Sistemi Idraulici S.p.A.

# ITRunner®

AZIENDA CON SISTEMA  
DI GESTIONE QUALITÀ  
CERTIFICATO DA DNV  
= ISO 9001 =

## 2 AXLES HOOKLIFT TRAILER ITR « 10.16 » MECHANIC SUSPENSIONS ARTICULATED ARM

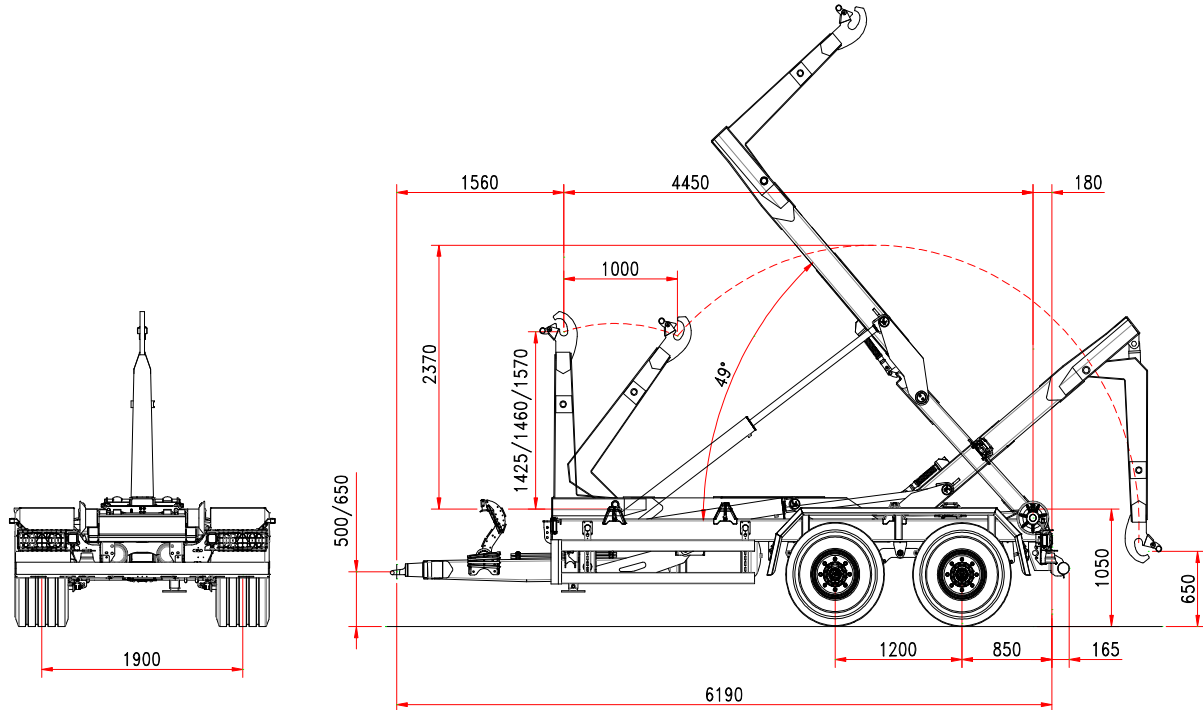

STANDARD FEATURES		ARTICULATED ARM	run 1.000 mm.
<b>CHASSIS</b>		Hook level	1.425/1.460/1.570
Frame section	200 x 100	Container external locking	hydraulic
Draw bar	silent blocks	Tipping angle	49°
Leaf spring suspension (Tandem)	16 ton	Tipping capacity	10 ton
Axles WHB	1.200 mm.	Lifting capacity	10 ton
Axles section	2 x 100		
Axles	fixed + fixed	<b>OLEO DYNAMIC SYSTEM</b>	
Track	1900	Tractor hydraulic	3 controls double acting
Brake drum	350 x 90	Oil volume (hook lift filled)	30 lt.
Braking system	hydraulic	Cylinders oil operation demand:	
Towing eye	turning type	Tipping	6,8 lt
Support foot	hydraulic	Load / unload	7,4 lt.
Wheels size	500/50-17	Tipping / loading max pressure	160/180 bar
Chassis loading level	1.050 mm		
<b>WEIGHT AND DIMENSIONS</b>			
Gross Trailer Weight (G.T.W)	16 ton		
Container handling cap.	3.500/5.500 mm.		
Max speed	40 Km/h		
(* )Tare	3.500 kg		

Edit 06/2013

(\* ) The trailer tare is referred to the basic unit without options & accessories

The technical details shown in this sheet are indicative and can be changed by the builder without prior notice.

**B.O.B. Sistemi Idraulici S.p.A.** – Regione Oltre Rea, 32 – 12060 Monchiero (CN) – Italia

P. I.V.A. 00496180043 – Tel.: +39 (0173) 780002/3 – Fax: +39 (0173) 780004

Internet: [www.bobspa.com](http://www.bobspa.com) – e-mail: [info@bobitalev.com](mailto:info@bobitalev.com)